

DIGITAL LIGHT METER KEW 5204 / 5204BT

Wide range and precise illuminance measurement
Streamlines report creation



- **Wide range illuminance measurement 0.0 to 199900 lx**
- **With auto zero adjustment function to achieve precise measurements**
- **Detachable & Rotatable Light Sensor**

- **Capable of measuring LED illuminance**
- **MAX/MIN Function**
- **Large LCD with Backlight**
- **Bluetooth communication function (5204BT only)**

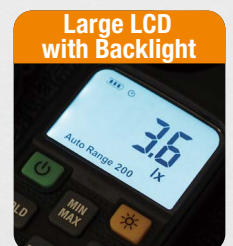

● KEW 5204 / 5204BT Specification

Light detector	Silicon photo diode
Measuring range	0.0 to 199900 lx
Range	199.9/1999/19990/199900 lx
Resolution	0.1 lx
Accuracy	±4%rdg±5dgt (23°C±2°C)
Angle deviation from cosine characteristics	10° ±1.5%, 30° ±3%, 60° ±10%, 80° ±30%
Temperature characteristics	±5% (at 23°C reference and a range of 0 to 40°C)
Relative spectral sensitivity characteristics	Deviation from spectral luminous efficiency: 9%
Response time	Auto range: 5s or less Manual range: 2s or less
Operating temperature and humidity range	0 to 40°C, relative humidity 80% or less (no condensation)
Storage temperature and humidity range	-10 to 60°C, relative humidity 70% or less (no condensation)
Auto power off	30 min.
Applicable standards	IEC 61326
Communication interface*	Bluetooth®
Power source	R6/LR6(AA)(1.5V) × 2
Dimension / Weight	169 (L) x 63 (W) x 37 (D) mm / Approx. 210g
Accessories	9195(Carrying case), Instruction manual LR6(AA) × 2

* LED illuminance measurements are verified by testing only the typical illuminance, frequency, and duty ratio of pulsed white LED.
 ** 5204BT only
 Bluetooth is a trademark or registered trademark of Bluetooth SIG, Inc. Android is a trademark or registered trademark of Google Inc. IOS is a trademark or registered trademark of Cisco Technology, Inc. in the United States and other countries.

● Relative Spectral Response Characteristics in the Visible Spectrum

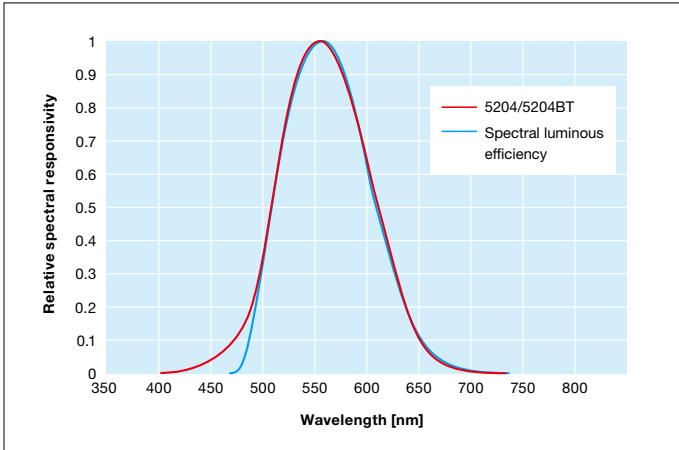

● Adequate Light Levels for Your Working or at Your Work Areas

LUXES (lx)	3,000	2,000	1,500	1,000	750	500	300	200	150	100	75	50	30	20	15
OFFICE				Entrance hall (day-time) Director room	Inquiry office Dining room Night-duty room	Stair									
				Council room Electrical computer room Reception room Guard station	Library, Tearoom Dressing room Toilet, lavatory	Warehouse, Lift, Passage									
FACTORY		Extra fine visual work	Design room Drawing room		Control room, Electric room Air conditioning machine room, lavatory, Toilet	Entrance Passage Path Warehouse									
SCHOOL			Drawing room		Classroom, Faculty room, Dining room, Gymnasium Night-duty room	Stair									
				Clothing classroom, Electronic computer room Experimental laboratory Reading room Health care room	Auditorium, Assembly room Locker room lavatory, Toilet	Passage									

! Safety Warnings :

Please read the "Safety Warnings" in the instruction manual supplied with the instrument thoroughly and completely for correct use. Failure to follow the safety rules can cause fire, trouble, electrical shock, etc. Therefore, make sure to operate the instrument on a correct power supply and voltage rating marked on each instrument.

KEW Smart Advanced application streamlines report creation.

Download and install our special application "KEW Smart Advanced" in your smartphone or tablet device for logging the measured values. Measured values can be saved in your smartphone or tablet device in csv format: the data is editable in excel format.

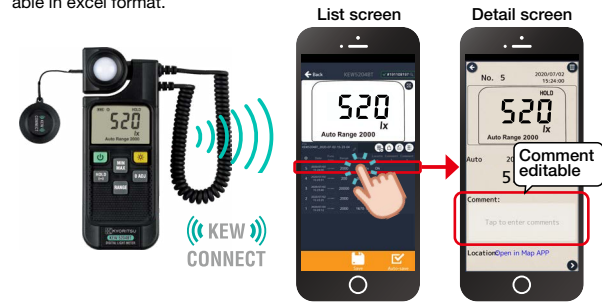

Please search **KEW Smart Advanced**



Application for Android

Free Android software "KEW Smart Advanced" is available on "Google Play Store".



Application for iOS

Free iOS software "KEW Smart Advanced" is available on "App Store".

Detachable & Rotatable Light Sensor

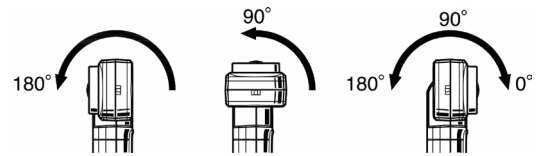

Light sensing probe can be angled while fixed to the main unit. The probe can also be detached for use.

Name of Parts and Position

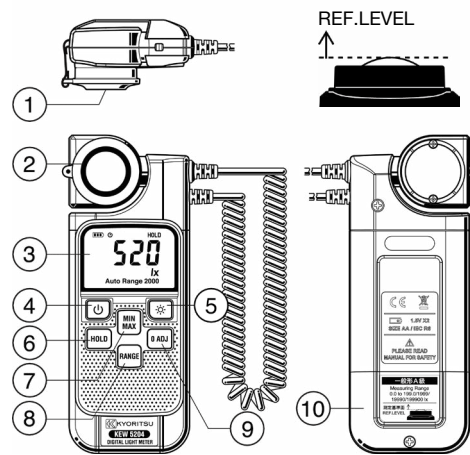

- ① Lens Protecting Cover
- ② Light Sensing Probe/Photocell
- ③ LCD Display
- ④ Power button
- ⑤ Backlight button
- ⑥ HOLD button
- ⑦ Max/Min button
- ⑧ Range selector button
- ⑨ 0 ADJ button
- ⑩ Battery cabinet cover

**COSINUS Messtechnik - Ihr Partner für Messlösungen
in allen elektrischen und physikalischen Anwendungen**

COSINUS Messtechnik GmbH

Rotwandweg 4

82024 Taufkirchen

Tel.: 089 / 66 55 94 - 0

Fax: 089 / 66 55 94 -30

office@cosinus.de
www.cosinus.de