

## HG561H

Pocket size, 7 test voltage ranges

- Test voltage selection mode
- LED level meter shows MΩ
- Easy-to-read LCD with fixed decimal point
- Automatic data hold function
- LCD with backlight & LED light for dark place

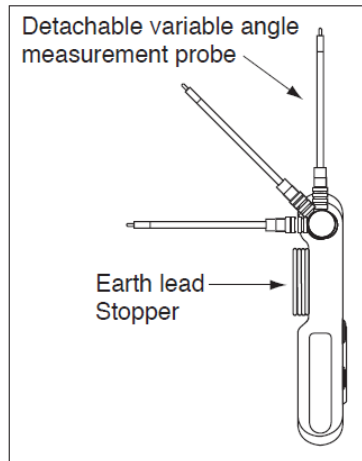

**Sampling rate** : approx. 2 times / sec.

**Safety** : IEC61010 CAT.III 300V CAT.II 600V



AP OFF

DATA HOLD

BACK LIGHT

AD

AUTO

15V  
21M Ω

25V  
21M Ω

50V  
21M Ω

100V  
110M Ω

125V  
110M Ω

250V  
110M Ω

500V  
110M Ω

HG561H	Measuring range	Best accuracy	Resolution
MΩ	15/25/50V 9.99M/21.0M Ω 100/125/250/500V 9.99M/99.9M/110M Ω	±(2%+5)	0.1M Ω
Test voltage	15/25/50/100/125/250/500V		
ACV/DCV	600V (AC/DC Automatic Detection)	±(1.6%+7)	0.1V
Ω	999.9/99.99k/999.9k Ω	±(1.5%+7)	0.1 Ω
Insulation Resistance (Level meter)	15/25/50V 5 Levels(LED light up/blinking) 100/125/250/500V 7 Levels(LED light up/blinking)		
Continuity	Buzzer sounds at 30 Ω or less		
Rated current	1.0~1.2mA		
Battery	LR03×4		
Size / Mass	H139×W91×D29mm/approx. 230g		
Standard accessories included	Measurement probe (TL-561), Alligator clip (CL-561), Carrying case (C-DG3a), Instruction manual		